



KINGS WAY PRIMARY SCHOOL

P. 1 HOLIDAY REVISION 2020-(SET TWO)

Mathematics.

Name: _____ Stream: _____

SECTION A (1 mark each)

1. Count and write:



2. Write the missing numbers: 3, 4, _____, 6, 7, _____.

3. Name the shape shown below:



4. Add: $3 + 2 =$ _____

5. Write 11 in words. _____

6. What number comes before 9?

7. Arrange from smallest to the biggest:

9, 3, 6, 1: _____

8. Write 13 in words.

9. Take away: $6 - 6 =$ _____

10. Tell the time on the clock face.



Its is _____ o'clock.

11. What number comes after 6?

12. How many groups of 2 can you count?

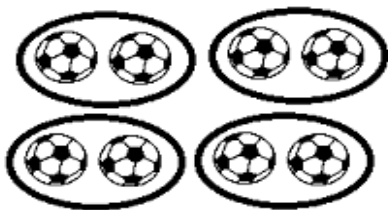

= _____

13. Draw a rectangle in the space below.

14. Cross out to make them 5.



15. Draw to make them 7.

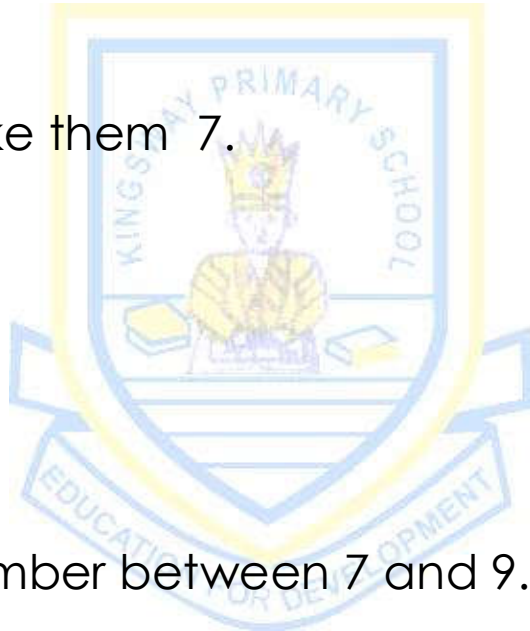
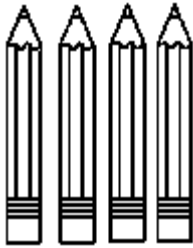

16. Write the number between 7 and 9. _____

17. Circle the smaller number.

7 , 9

18. Multiply: $4 \times 2 =$ _____

19. Draw 7 cats.

20. What is 9 take away 2?

Section B



21. **Match correctly:**

(a) 5 eleven

(b) 15 three

(c) 3 five

(d) 11 fifteen

22. Take away (subtract):

(a) $7 - 7 =$ _____

(b) $6 - 0 =$ _____

(c)
$$\begin{array}{r} 9 \\ -5 \\ \hline \\ \hline \end{array}$$

(d) Ann has 5 sweets. She gives 3 sweets to Mary. How many sweets does she remain with?

23(a) Name the shapes drawn below.

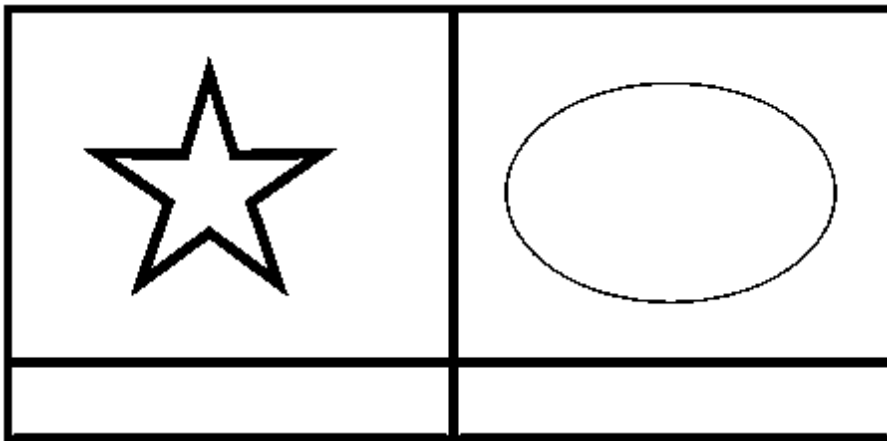

(b) Draw the shapes named below.



24. Add:

(a) $1 + 3 + 2 =$ _____ (b) $6 + 3 =$ _____

(c)
$$\begin{array}{r} 5 \\ + 0 \\ \hline \\ \hline \end{array}$$

(d) Musa has 4 apples . He gets 4 more apples. How many apples does he have altogether?

25. Write "Yes" or "No" .

(a)  This is a circle. _____

(b) Two plus three equals five. _____

(c) Seven take away zero equals nine. _____

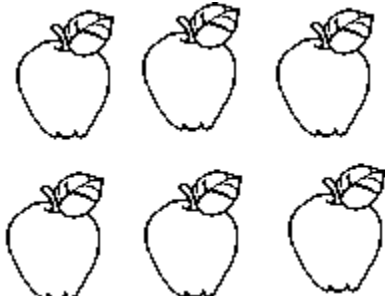
(d)  There are seven apples. _____

26. How many can you count?

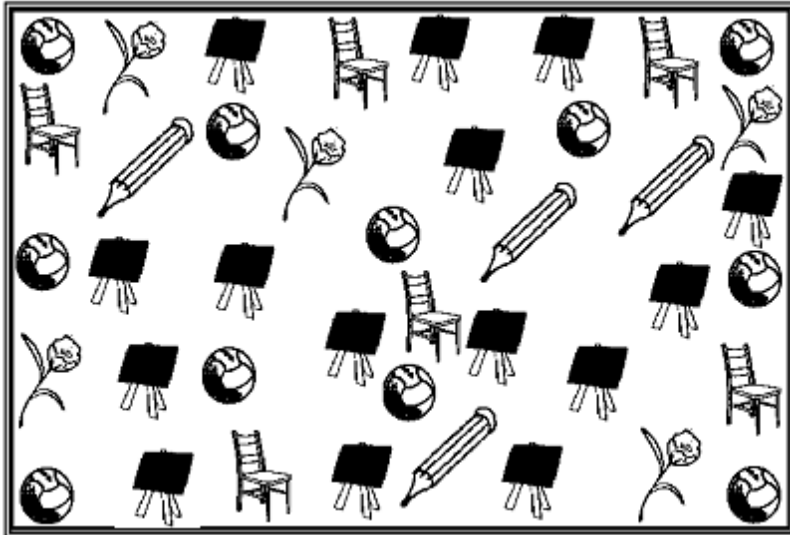

(a) How many  can you count? _____

(b) How many  can you count? _____

(c) How many  can you count? _____

(d) How many  can you count? _____

27. Write the numbers in words.

(a) 9: _____

(b) 13: _____

(c) 11: _____



(d) 7: _____

28. Fill in the missing numbers.

(a) $\underline{\quad} + \underline{\quad} = 3$ (b) $\underline{\quad} - \underline{\quad} = 2$

(c) $\underline{\quad} + 0 = 5$ (d) $\underline{\quad} - 0 = 4$

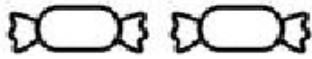
29. The graph shows the number of sweets each of the four children has.

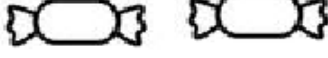
Name	Number of sweets
Ali	
Juma	
Jane	
Ann	

(a) Who have the same number of sweets?

(b) How many sweets does Ali have?

(c) Who has one sweet?

(d) How many sweets do Jane and Ann have altogether?

30(a) Arrange from biggest to the smallest.

19, 11, 15, 17: _____

(b) Circle the smaller number.

8, 13

(c) Write the missing numbers:

18, 17, _____, 15, _____.

(d) What number comes before 20?

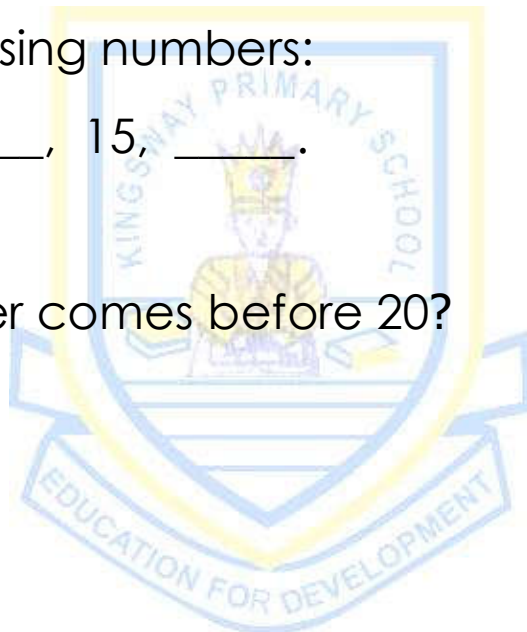



KINGS WAY PRIMARY SCHOOL

P. 1 HOLIDAY REVISION 2020-(SET TWO)

English

Name: _____ Stream: _____

1. **Listen and write.**

(a) _____

(c) _____

2. **Write the words correctly.**

(a) b___ ___ k (b) p___ n___ il

3. **Write the words in small letters.**

(a) CAT: _____ (b) HOUSE: _____

4. **Use a correct word to fill the gaps.**

(a) Tom _____ reading a book.

(b) She _____ a big bag.

(c) He is eating _____ egg.

(d) The boys _____ playing.

(e) We use a _____ to write in our books.

5. **Arrange the words in alphabetical order.**

(a) nurse, cook, bursar

(b) bus, big, bag

6. **Use the given words to write sentences.**

(a) two: _____

(b) to: _____

7. **Re-arrange the words to form sentences.**

(a) pot is in The a flower.

(b) your Who teacher is?

(c) has Mary box a.

8. **Use 'These', 'This', 'a', 'an', 'is' or 'are' to fill the gaps.**

(a) She is eating _____ orange.

(b) _____ is a book.

(c) The boys _____ reading.

(d) He is writing with _____ pencil.

(e) _____ are flowers.

(f) A cow _____ an animal.

9. **Use the correct form of the word in brackets to fill the gaps.**

(a) The dogs _____ eating meat. (is)

(b) The girls _____ balls. (has)

(c) I _____ a boy. (is)

10. **Give the plural form of the underlined word.**

(a) The teacher has a box. _____

(b) That is a cat. _____

(c) He goes to church on Sunday. _____

11. **Circle the different word.**

(a) ten, write, three, eight

(b) chair, stool, bench, stone

12. **Complete the sentences about the pictures.**

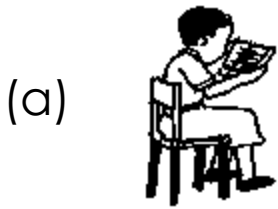

Mary is _____ a book.



The cat is _____ the table.

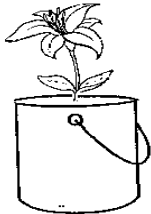

The _____ is in the tin

13. **Use a capital letter to rewrite the sentence.**

(a) this is a tree.

(b) Give the book to mariam.

14. **Fill the gaps in the story with the given words.**

(lives, teacher , father, is , He)

David _____ a boy. _____ is nine years old.
He _____ at Ndeeba. His _____ is
Mr. Muntu. He is a _____.

15. **Match correctly.**

- (a) Tom is _____ trees.
(b) These are _____ writing in a book.
(c) One plus two _____ to learn.
(d) We go to school _____ equals three.

16. **Read the story and answer the questions.**

My name is Ali. I am a boy. I am six years old. I go to
Kampi Primary School. I am in P. 1. I live at Mende.
My father is Mr. Matu. He is a teacher.

Questions:

(a) What is the name of the boy in the story?

(b) How old is Ali?

(d) Where does Ali live?

(e) In which class is Ali?



KINGS WAY PRIMARY SCHOOL

P. 1 HOLIDAY REVISION 2020-(SET TWO)

Literacy I

Name: _____ Stream: _____

1. Listen and write.

(a) _____

(c) _____

2. Name the given pictures.

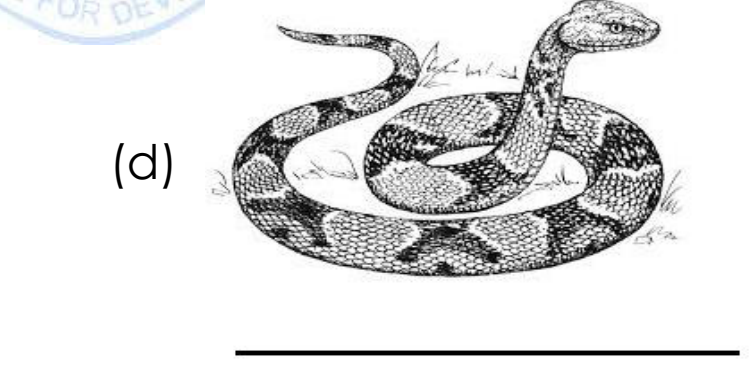
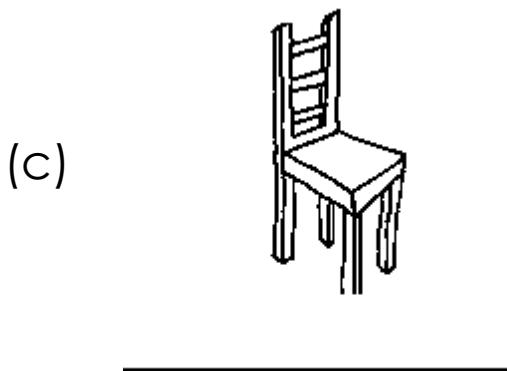
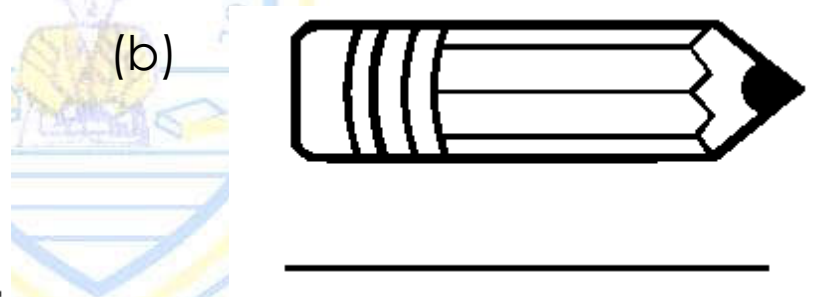
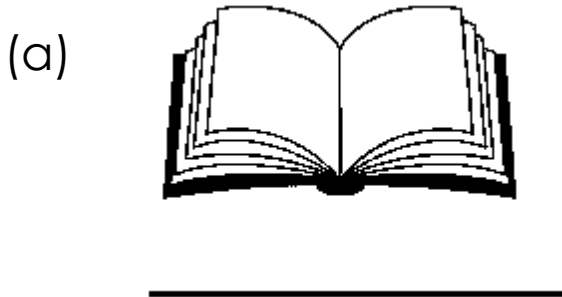

3. Fill in the missing letters to form words.

(a) ch__ __k

(b) h__u__e

(c) e: _____

6. **Complete the gaps correctly.**

(a) A cat eats _____.

(b) We use our _____ to walk.

(c) A cow has _____ legs.

7. **Read and draw pictures.**

(a) The ball is under the table.



(b) I can see three trees.

(c) A flower is in the tin.

(d) She has four cats.

8. Join the letters to make four correct words.

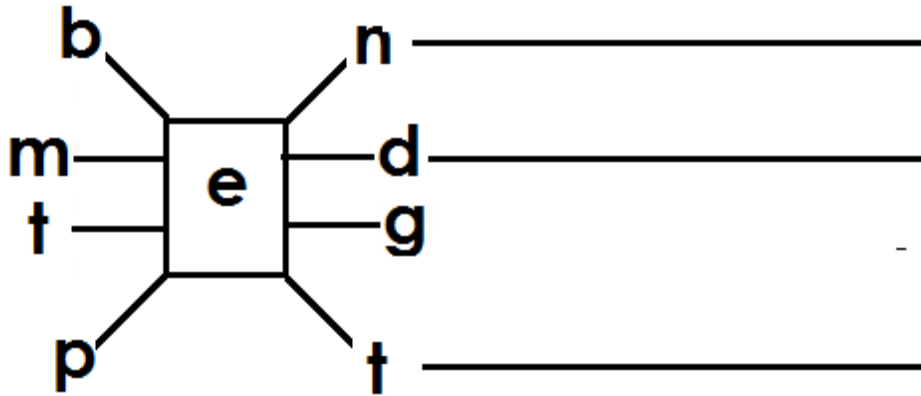

9. Write sentences about the picture.

(a)



(b)



(c)



-
10. Circle two words in the letter table and write them down.

c	l	a	s	s	r	o	o	m	b
h	e	n	e	l	e	v	e	n	l
a	d	d	v	n	u	r	s	e	a
l	o	v	e	i	t	e	a	s	c
k	n	a	n	i	n	e	n	t	k
p	e	n	c	i	l	l	d	o	t
d	u	s	t	e	r	a	t	w	o

(a) _____ (b) _____

11. Write two small words from the given word without changing the order of the letters.
teacher

(a) _____ (b) _____

12. Use the given letters to write two words.

t, a, m, e

(a) _____ (b) _____

13. **Complete the word puzzle correctly.**

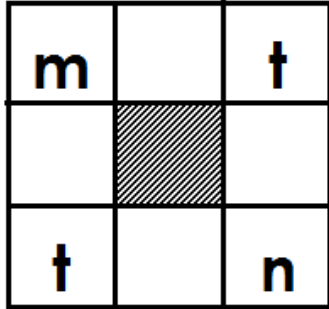

14. **Write Yes or No to fill the gaps.**

(a) A nurse treats sick children. _____

(b) A child has two eyes. _____

15. **Write words of three letters from the word wheel.**

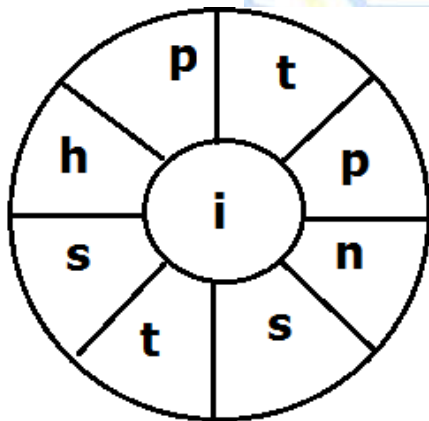

a. _____

b. _____

c. _____

17. **Use the correct word from the brackets to fill the gaps.**

(a) The _____ is in the sky. (son, sun)

(b) My father lives in a _____. (hut, hat)

(c) He has _____ water in the cup. (some, sum)



KINGS WAY PRIMARY SCHOOL

P. 1 HOLIDAY REVISION 2020-(SET TWO)

Literacy II

Name: _____ Stream: _____

SECTION A (2 marks each)

1. Listen and write:

2. Write down the name of our school.

3. Give one use of water in a school.

4. Write down one way children come to school.

5. Name the animal in the picture.



6. What do children use to write in their books?

7. Give one thing (activity) children do at school.

8. Draw a picture of tree in the space below.

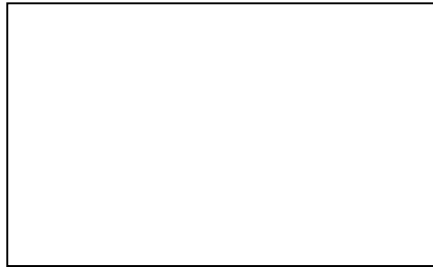

9. Write one thing children use to play at school.

10. Who is the head of a school?

11. Write any one activity children do in class.

12. Name one thing found in the dining hall.

13. Mention the body part we use to walk.

14. Write one thing we use to keep the classroom clean.

15. Who treats sick children in a school?

16. Name the place where children go to learn.

17. Write the dangerous thing shown below.



18. Duster is to blackboard as rubber is to _____.

19. Give the use of money in a school.

20. What is the work of teacher in a school?

SECTION B (2 marks each)

21. Name the things you see on your way to school.

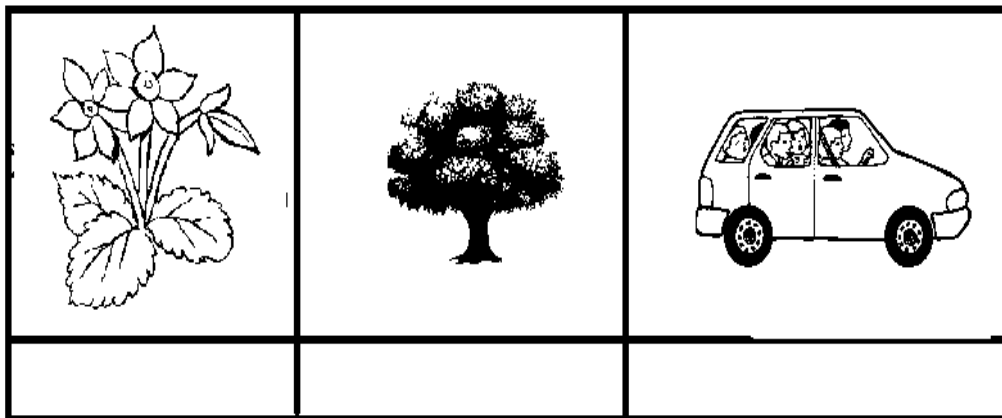

22. Name three animals found in a home.

(a) _____ (b) _____

(c) _____

23. **Match correctly.**

Person

Place of work

(a) teacher

medicine

(b) nurse

broom

(c) cleaner

chalk

24. Draw these things we use at home.

chair	house	cups

25. Name three things found in a classroom.

(a) _____ (b) _____

(c) _____

26. Give the body part used to do the following:

(a) hearing music: _____

(b) writing in a book: _____

(c) chewing food: _____

27. **Write 'Yes' or 'No' to fill the gaps.**

(a) We find cows in the classroom. _____

(b) A school nurse works in the sickbay. _____

(c) Children use stones to write in their books. _____

28. **Name the body parts.**

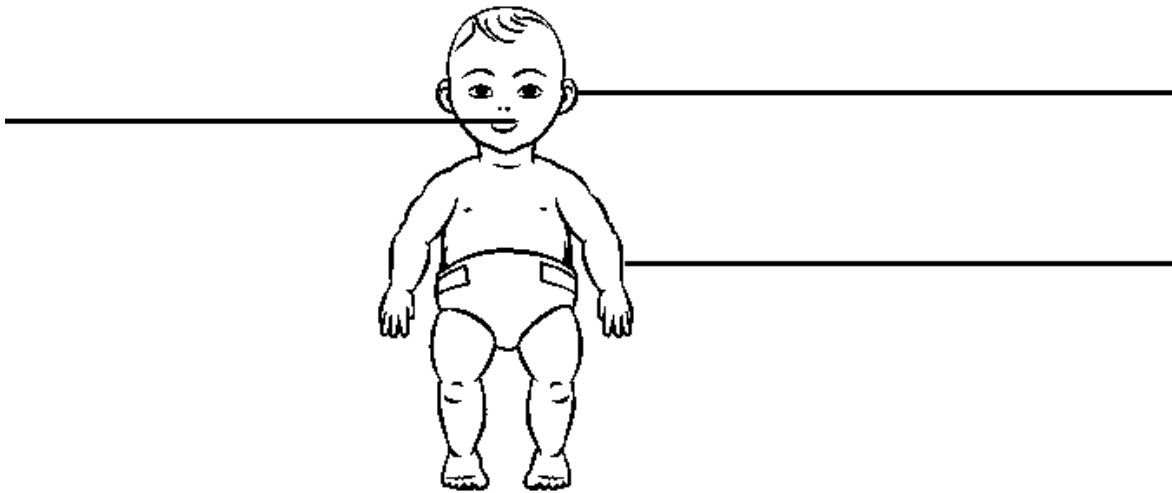

29. What things do we use for the following?

(a) Keeping water for drinking

(b) washing things

(c) living in

30. Give three things found in the school compound.

(a) _____ (b) _____

(c) _____