



KINGS WAY PRIMARY SCHOOL

P. 1 HOLIDAY REVISION 2020-(SET THREE)

English

Name: _____ Stream: _____

1. **Listen and write.**

(a) _____

(b) _____

2. **Fill in the missing letters.**

(a) b___ y

(b) b___ k

(c) ch___ l___

3. **Write the words in small letters.**

(a) MAT: _____ (b) CLEAN: _____

4. **Use a correct word to fill the gaps.**

(a) He is sitting _____ a chair.

(b) We use pencils to _____ in our books.

(c) Ali _____ reading a book.

(d) The boy _____ a ball.

5. **Use the given words to write sentences.**

(a) This: _____

(b) These: _____

6. **Arrange the words in alphabetical order.**

(a) door, bag, cat, ant

(b) pot, dog, mat, bat

7. **Arrange the words to make sentences.**

(a) is years old five Tom.

(b) bag is This a.

8. **Complete the sentences about the pictures.**

(a)  He is _____ a banana

(b)  Mary is reading a _____.

(c)  She sleeping in a _____.

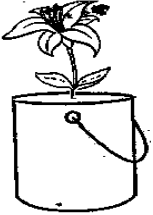

(d) The cat is _____ the table.

(e)  The _____ is in the tin

8. **Use 'These', 'This', 'a', 'an', 'is' or 'are' to fill the gaps.**

(a) She is eating _____ orange.

(b) _____ is a book.

(c) He is writing with _____ pencil.

(d) _____ are flowers.

(e) A cow _____ an animal.

9. **Use the correct form of the word in brackets to fill the gaps.**

(a) The girls _____ balls. (has)

(b) I _____ a boy. (is)

(c) _____ is an apple. (These)

(d) He has two _____. (bag)

10. **Give the plural form of these words.**

(a) box- _____

(b) cat- _____

(c) man - _____

11. **Circle the different word.**

(a) one, read, seven, four

(b) boy, cat, dog, rat

12. **Give the picture number.**

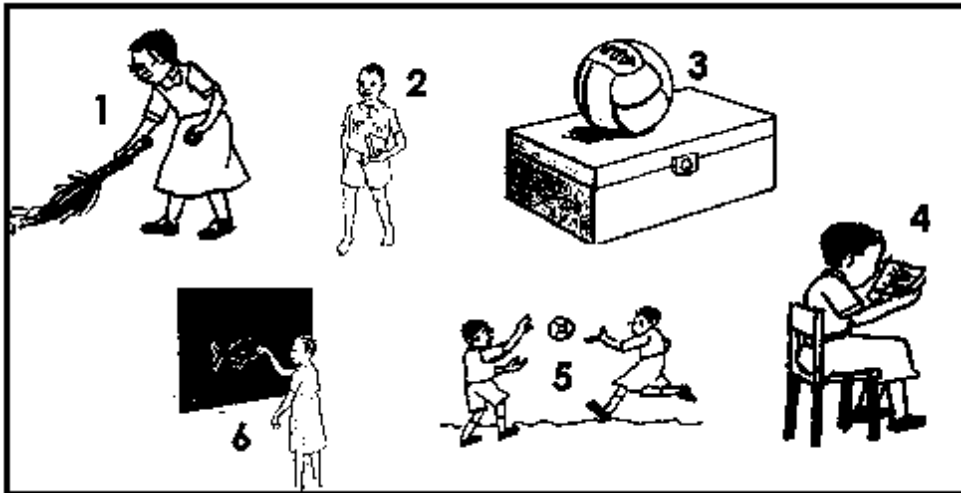

(a) She is reading a book. Number _____

(b) The ball is on a box. Number _____

(c) They are playing with a ball. Number _____

(d) Mary is sweeping with a broom. Number _____

14. **Use the given words to fill the gaps in the story.**

six , in , name, am , have

My _____ is Tuti. I _____ a girl. I am
_____ years old. I am _____ Primary One. I
_____ a bag and three books.

15. **Match correctly.**

- (a) We go to school _____ is your name?
(b) What _____ has a bag.
(c) Tom _____ to learn.

16. **Read the story and answer the questions.**

Tom is a boy. He is six years old. He is in primary one.
His father has a red car. It has four wheels. The car
has two doors.

Questions:

- (a) What is the name of the boy in the story?

- (b) How old is he?

- (c) In which class is Tom?





KINGS WAY PRIMARY SCHOOL

P. 1 HOLIDAY REVISION 2020-(SET THREE)

Literacy I

Name: _____ Stream: _____

1. Listen and write. (2 marks each)

(a) _____

(c) _____

2. Name the given pictures.(1 mark each)

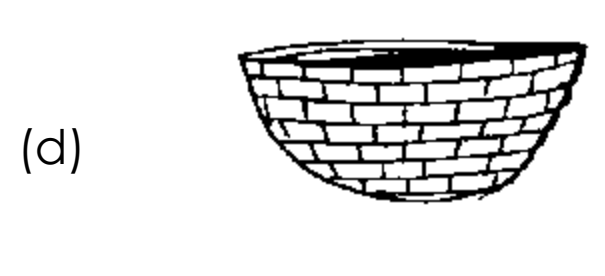
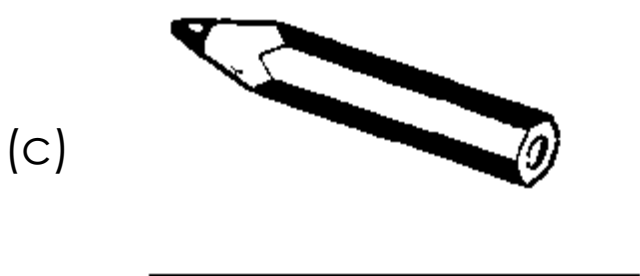
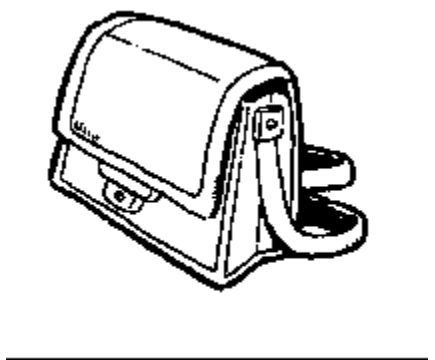
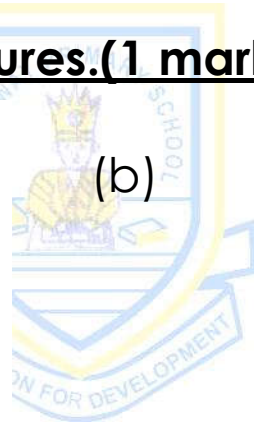
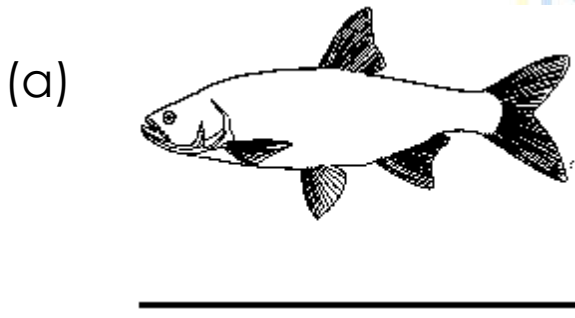

3. Write the words correctly. (2 marks each)

(a) obok: _____ (b) anem: _____

(c) oyb: _____ (d) rete: _____

4(a) Copy the given letters correctly. (1 mark each)

Ss Ss Ss Ss

(b) Copy the give words correctly.

snail nest school

(c) Copy the given pattern correctly.

S S S S S

(d) Copy the given sentence correctly.

A snail has a shell.

5. **Use the given sounds to write words. (1 mark each)**

(a) c: _____ (b) b: _____

(c) a: _____ (d) e: _____

6. **Answer the questions correctly. (2 marks each)**

(a)  Where is the ball?

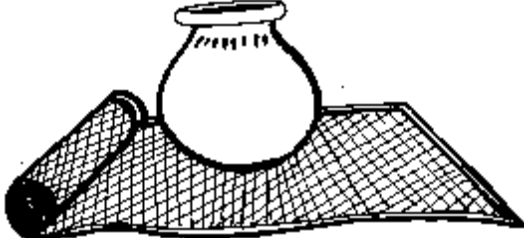
(b)  Where is the pot?

(c)  What is the girl doing?

(d)  What is the woman doing?

7. **Complete the gaps correctly. (2 marks each)**

- (a) The teacher is sitting _____ a chair.
- (b) We use our _____ to see.
- (c) We write in _____ at school.

8. **Read and draw pictures. (1 mark each)**

- (a) The ball is on a chair.

- (b) I can see two girls.



- (c) A flower is in the tin.

- (d) She has bag.

9. Join the letters to make four correct words.

(1 mark each)

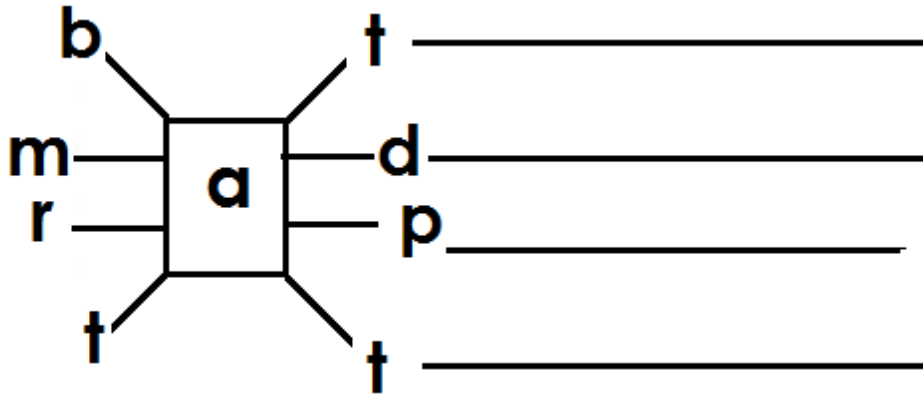

10. Write the names of things in our classroom from the letter table.(2 marks each)

c	h	a	i	r	b	o	o	k
h	s	t	o	o	l	n	t	p
a	p	e	n	c	i	l	a	e
l	o	d	e	s	k	t	b	n
k	t	o	s	i	n	k	l	p
d	u	s	t	e	r	c	e	y

(a) _____

(b) _____

(c) _____

(d) _____

11. Write two small words from the given word without changing the order of the letters. (2 marks each)
satpin

(a) _____ (b) _____

12. Use the given letters to write two words.

(2 marks each)

s , m, a, t, e, r

(a) _____ (b) _____

(c) _____

13. Choose the correct word to fill the gaps.

(a) The _____ gives us light. (son, sun)

(b) He has a _____ on his head. (hat , hut)

(d) A _____ eats rats. (cat cut)

14. Complete the word puzzle correctly.(2 marks each)

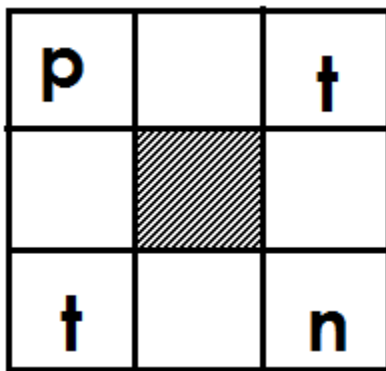

15. Write Yes or No to fill the gaps. (2 marks each)

(a) We write in books. _____

(b) A child has two legs. _____

(c) Teachers work in schools. _____

16. **Write a new word using these letters. (2 marks each)**

(a) net: _____ (b) no: _____

(c) pat: _____ (d) top: _____

17. **Write words of three letters from the word wheel.**

(1 mark each)

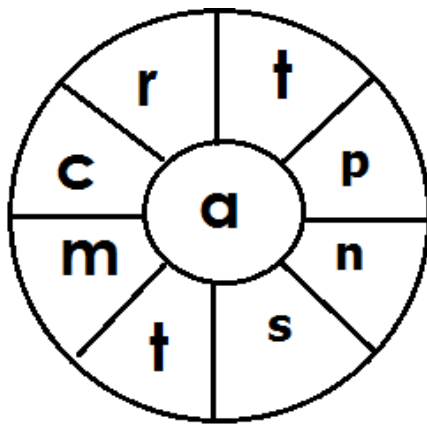

(a) _____

(b) _____

(c) _____

(d) _____



KINGS WAY PRIMARY SCHOOL

P. 1 HOLIDAY REVISION 2020-(SET THREE)

Literacy II

Name: _____ Stream: _____

SECTION A (2 marks each)

1. Name any one thing found in a classroom.

2. What do school children use to write in books?

3. Write the name of our school.

4. Give one way people use brooms at school.

5. Nurse is to a sickbay as _____ is to a classroom.

6. Give one activity children do at school.

7. Name the picture drawn below.

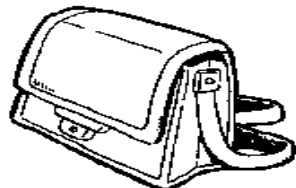

8. Name one thing children use to play at school.

9. Draw a picture of a book in the space below.



10. Who treats sick children in a school?

11. Name the part of the body we use to see.

12. Write one item teachers use to do work.

13. Name the thing children use to come to school.



14. Give any one use of water in a school.

15. Name one thing we use to drink water.

16. Draw a picture of a tree in the space below.



17. Give any one item found in a school library.

18. Who heads a school?

19. Write any one activity children do in a classroom.

20. Mention any one thing found in the dining hall.

SECTION B: (2 marks each)

21 (a) Where do children go to learn?

(b) Write one group of people found in a school.

(c) Where is food cooked in a school?

22(a) Name the things in a class we use:

(i) sitting on: _____

(ii) writing on the blackboard: _____

(b) Give one duty of a teacher in a school.

23(a) Name the members of a nuclear family in the picture below.

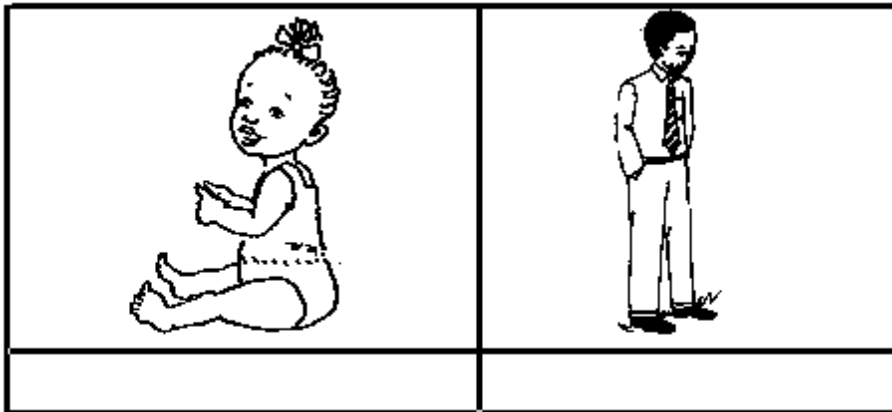

(b) Give the work of a mother in a home.

24(a) Name any two things found in a house.

(i) _____ (ii) _____

(b) Give one use of a house to people in a home.

25(a) Name one item we use to clean our teeth.

(b) Give the body part we clean using a comb.

(c) Mention the part of the body we use for walking.

26. **Match A to B.**

A

B

(a) bursar

classroom

(b) teacher

sickbay

(c) school nurse

office

27. Draw the following pictures:

cup	tree	cat

28(a) Write two things you see on your way to school.

(i) _____ (ii) _____

(b) Name one way children come to school.

29. **Write "True" or "False".**

(a) Children use ears to chew food. _____

(b) A bursar collects school fees. _____

(c) A teacher uses chalk to write on the blackboard.

30. Name any three animals kept in a home.

(a) _____ (b) _____

(c) _____





KINGS WAY PRIMARY SCHOOL

P. 1 HOLIDAY REVISION 2020-(SET THREE)

Mathematics

Name: _____ Stream: _____

SECTION A (1 mark each)

1. Count and write the number.

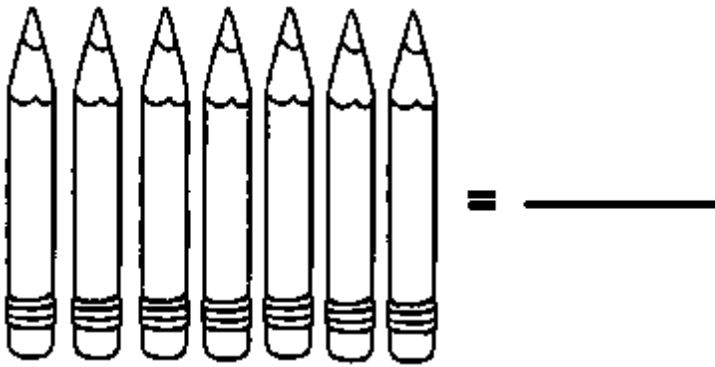

2. Fill in the missing numbers: 11 , 12 , _____ , 14.

3. Write '**nine**' in figures. _____

4. Which number comes before 7?

5. Add correctly. $6 + 3 =$ _____

6. Name the shape below.



7. Draw a group of 4 boys.

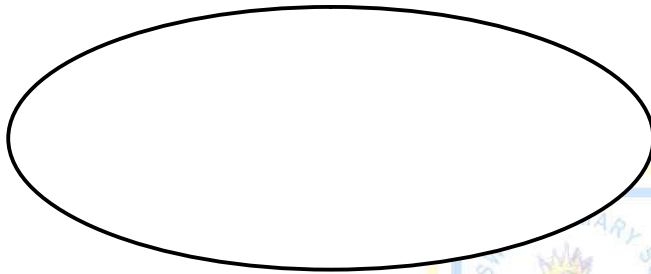

8. Arrange the numbers from biggest to smallest.

3, 7, 9, 8: _____

9. Take away: $5 - 0 =$ _____

10. What number comes between 11 and 13?

11. Write in words: 11 _____

12. What time is shown on the clock face?



13. Complete correctly:

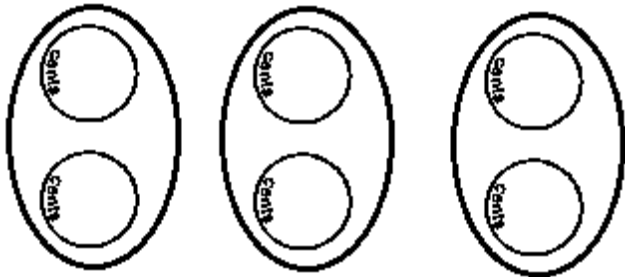

_____ + _____ + _____ = _____

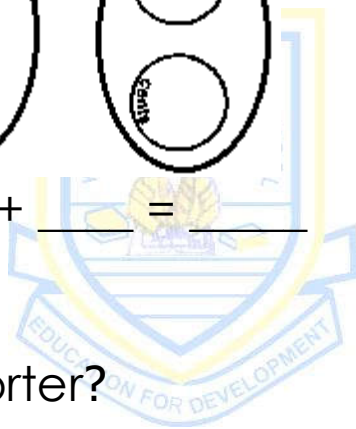

14. Which stick is shorter?

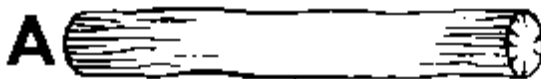

15. Cross out to make them 4.



16. Circle the smaller number.

9 , 13

17. Find the missing number

$$3 + \underline{\quad} = 5$$

18. What is 8 minus 3?



19. What day comes after Friday?

20. Draw to make them 5.



SECTION B: (2 marks each)

21. **Match correctly.**

three
twelve
eight
six

6
8
3
12

22. **Add correctly.**

(a) $4 + 2 + 3 =$ _____

(b) $1 + 7 =$ _____

(c)

$$\begin{array}{r} 3 \\ + 4 \\ \hline \end{array}$$

(d) 6 pens are in a tin and 6 pens are in a cup. Together there are _____ pens.

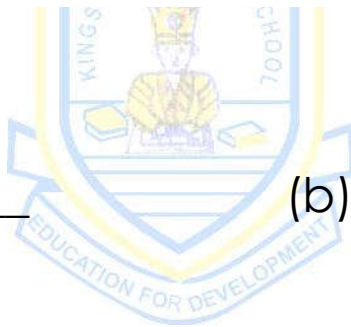

23(a) Name the shapes given below.

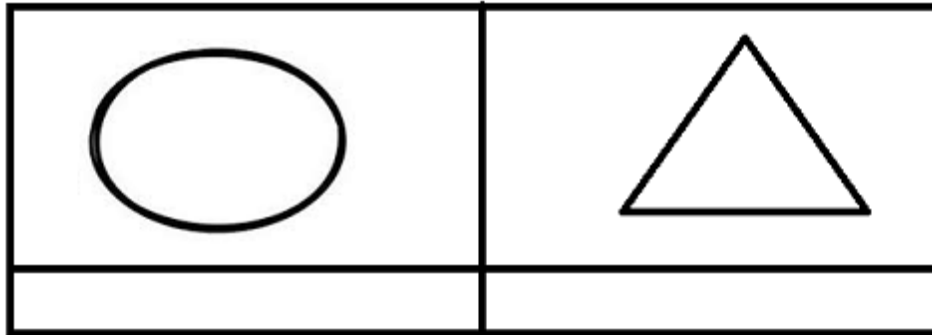

(b) Draw these shapes.

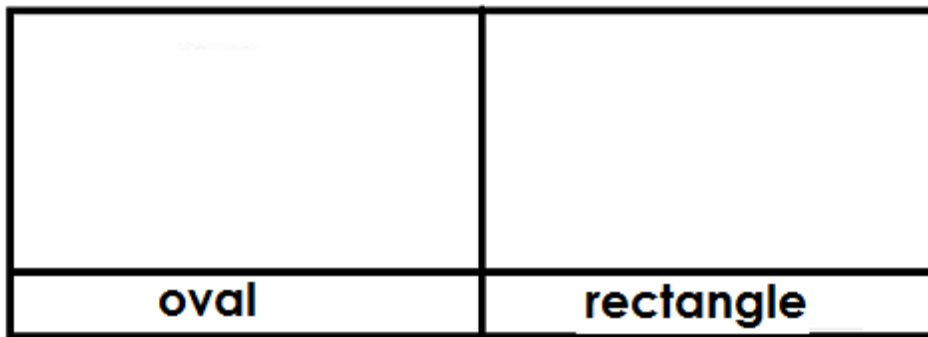

24. **Subtract (Take away).**

(a) $7 - 7 = \underline{\quad}$

(b) $9 - 0 = \underline{\quad}$

(c)

$$\begin{array}{r} 7 \\ - 3 \\ \hline \\ \hline \end{array}$$

(d) There are 5 oranges in a basket. Ali eats 2 oranges.
How many oranges are left?

25. Fill in the missing numbers.

(a) $\underline{\quad} + \underline{\quad} = 4$

(b) $\underline{\quad} - \underline{\quad} = 2$

(c) $\underline{\quad} \times \underline{\quad} = 6$

(d) $\underline{\quad} + 0 = 5$

26. Count and write the number.

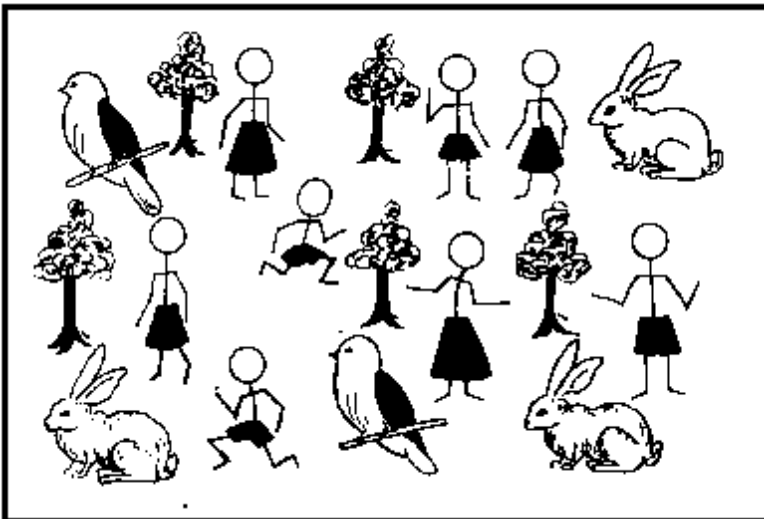

(a) How many  can you count?

(b) How many  can you count?

(c) How many  can you count?

(d) How many  can you count?

27. **Make groups of two.**



(a) How many groups are there?

(b) How many balls are there altogether?

(c) Multiply: $2 \times 2 =$ _____

(d) How many legs do 5 boys have?

28(a) Circle the numbers bigger than 3.

4, 0, 2, 6

(b) Arrange these numbers from smallest to the biggest.

1, 5, 10, 8 : _____

(c) Circle the numbers smaller than 5.

8, 3, 11, 1

(d) Fill in the missing numbers.

17, 16, _____, 14, _____, 12

29. Write 'Yes' or 'No' to fill the gaps.

(a)  This is a square. _____

(b) 5 is smaller than 2. _____

(c)  There are four balls in group A.

(d) Six minus 4 equals 2. _____

30. Four children have stars. Read and answer the questions.

Tom	☆ ☆ ☆ ☆
Ann	☆
Mary	☆ ☆
Juma	☆ ☆ ☆

(a) How many children have stars?

(b) Who has three stars?

(c) Who has the biggest number of stars?

(d) How many stars do the children have altogether?
